

# *937x-FB-XX-SS*

## *Fieldbus Barrier Assembly*

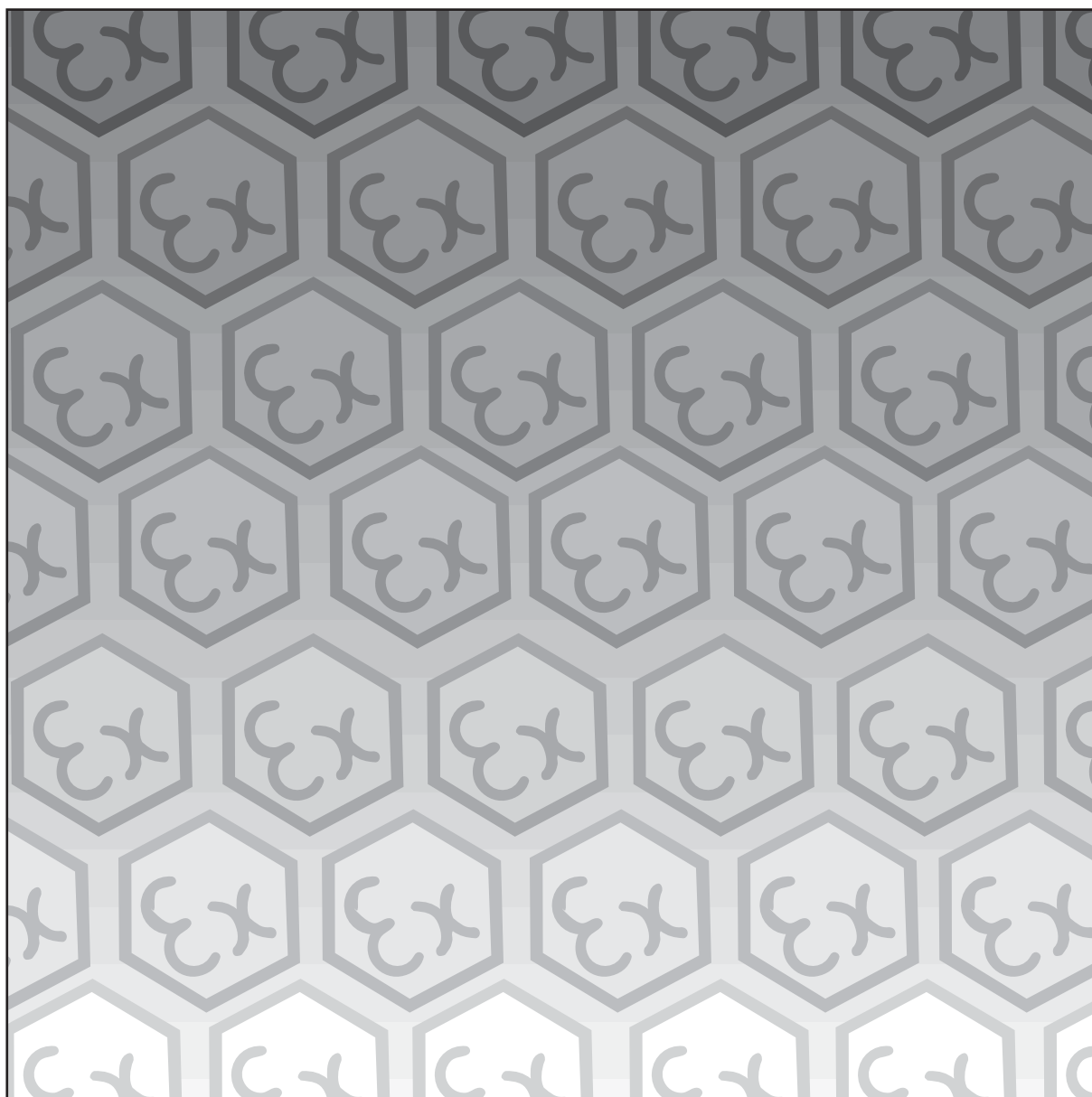

**Instruction Manual**

**INM9370-SS**





# CONTENTS

<b>1</b>	<b>OVERVIEW</b> .....	<b>1</b>
<b>2</b>	<b>DESCRIPTION</b> .....	<b>2</b>
<b>3</b>	<b>MECHANICAL INSTALLATION</b> .....	<b>2</b>
3.1	Mounting overview .....	2
3.2	Preparation .....	4
3.3	Mounting .....	4
<b>4</b>	<b>INITIAL ELECTRICAL INSTALLATION</b> .....	<b>5</b>
4.1	Overview .....	5
4.2	Grounding .....	5
4.3	Trunk connections .....	7
4.4	Trunk Terminator module 9378-FT .....	10
4.5	Trunk Surge module 9376-SP .....	10
4.6	Spur connections .....	10
4.7	Final checks .....	11
<b>5</b>	<b>MAINTENANCE</b> .....	<b>12</b>
5.1	General .....	12
5.2	Fieldbus Barrier - fitting and removal .....	12
5.3	Terminator and Trunk Surge Protection modules .....	13
5.4	Spur connections .....	14
5.5	Trunk connections .....	15
5.6	Regular Maintenance checks .....	15
<b>6</b>	<b>TROUBLESHOOTING</b> .....	<b>16</b>
<b>7</b>	<b>ATEX INFORMATION</b> .....	<b>17</b>
7.1	General .....	17
7.2	Installation .....	17
7.3	Inspection and maintenance .....	17
7.4	Repair .....	17
7.5	Marking .....	17
<b>8</b>	<b>APPENDIX 1 - ENCLOSURE WIRING DIAGRAMS</b> .....	<b>19</b>
8.1	Wiring diagram for 9371-FB-XX-SS .....	20
8.2	Wiring diagram for 9373-FB-XX-SS .....	21

## **GENERAL SAFETY INFORMATION**

### **Safety instructions for installation and operating personnel**

The operating instructions provided here contain **essential safety instructions** for installation personnel and those engaged in the operation, maintenance and servicing of the equipment.

<b>WARNING!</b>
<b>Failure to comply with these instructions can endanger the lives or health of personnel and risk damage to the plant and the environment.</b>

<b>WARNING!</b>
<b>The responsibility for planning, installation, commissioning, operation and maintenance, particularly with respect to applications in explosion-hazard areas, lies with the plant operator.</b>

#### **Before commencing installation or commissioning:**

- Read and understand the contents of this manual
- Ensure installation and operating personnel have received adequate training for this task
- Ensure that any operating instructions are fully understood by the personnel responsible.
- Observe national and local installation and mounting regulations (e.g. IEC 60079-14).

<b>WARNING!</b>
<b>These assemblies may not be used in explosion-hazard area applications if they have been used previously in general electrical installations.</b>

#### **During operation:**

- Make the relevant instructions available at all times to the operating personnel.
- Observe safety instructions.
- Observe national safety and accident prevention regulations.
- Operate the equipment within its published specification.
- Servicing, maintenance work or repairs not described in this manual must not be performed without prior agreement with the manufacturer.
- Any damage to this equipment may render its explosion protection null and void.
- No changes to any of the components that might impair their explosion protection are permitted.

#### **If any information provided here is not clear:**

- Contact MTL or one of its representatives.

**Note:** Improper installation and operation of the enclosure can result in the invalidation of the guarantee.

# 937X-FB-XX-SS Fieldbus Barrier 6- & 12-spur, stainless steel enclosure

INM9370-SS-1  
May 2010

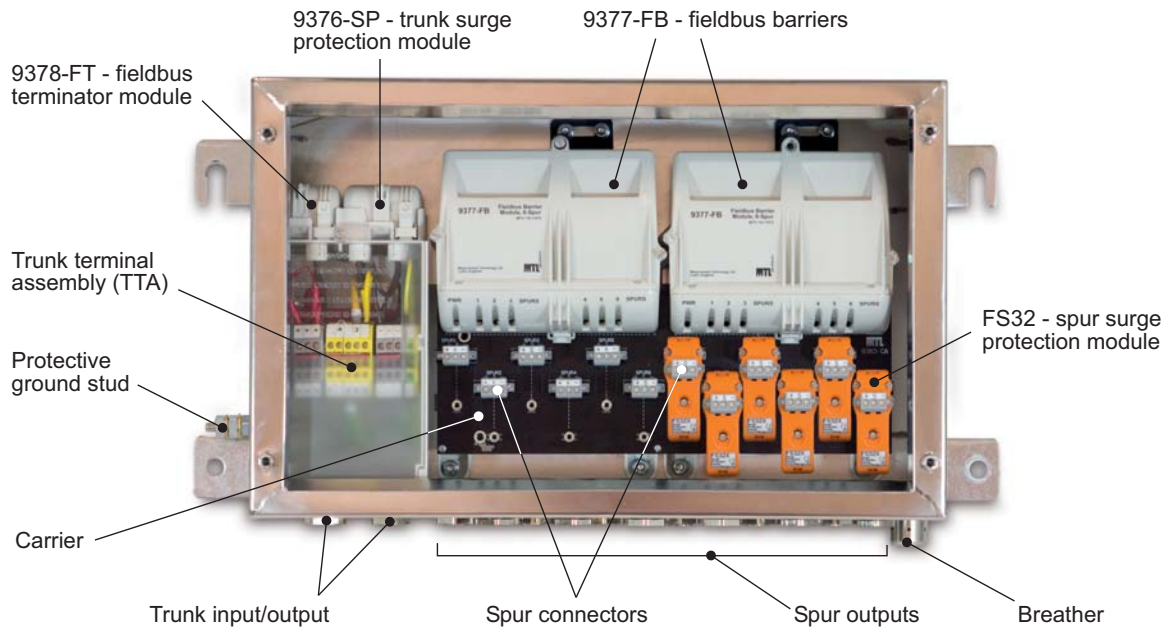

Figure 1.1 - Example of model 9373-FB-ST-SS with six FS32 spur surge protection modules

## 1 OVERVIEW

This manual explains the installation and maintenance procedures for the 937x-FB-XX-SS Fieldbus Barrier enclosures and must be read in association with the product datasheets that contain the electrical data.

The 9371-FB-XX-SS and 9373-FB-XX-SS Fieldbus Barrier enclosures are field-mounted wiring hubs that create six or twelve intrinsically safe spur connections, respectively, from a single non-intrinsically safe trunk, for connection to FOUNDATION™ fieldbus H1 fieldbus instruments. The incoming fieldbus trunk and the output spurs may optionally be fitted with surge-protection devices.

The enclosure material is electrochemically polished 316 stainless steel and may be installed in a Zone 1 or Zone 2 hazardous area.

The following enclosure types are available by ordering the appropriate model number.

9371-FB-XX-SS Fieldbus Barrier system, 6-spur, stainless steel enclosure

9373-FB-XX-SS Fieldbus Barrier system, 12-spur, stainless steel enclosure

Where XX = PS (pluggable screw terminal connectors) or  
PC (pluggable spring clamp connectors)

## 2 DESCRIPTION

The model numbers given comprise a stainless steel, increased safety, Ex e enclosure containing one or two carrier-mounted fieldbus barriers. A single barrier module converts a single, non-intrinsically safe fieldbus trunk into six intrinsically safe (IS) spur connections for connection to FOUNDATION™ fieldbus H1 fieldbus instruments.

Inside the enclosure, the incoming trunk wiring enters a separate compartment, called the Trunk Terminal Assembly (TTA) that contains increased safety (Ex e) trunk wiring terminals. This assembly has a protective cover to deter interference, and carries a warning to the user about working on trunk wiring without first isolating the power.

A fieldbus Terminator module (part no. 9378-FT) is supplied pre-fitted on the TTA. This is to remain installed if the enclosure is at the end of the segment. If the incoming fieldbus trunk will be onward linked to a further node on the segment the terminator can be removed.

The spurs are galvanically isolated from the trunk allowing the user to choose the type of grounding scheme most suitable to their system.

Spur short-circuit protection is provided by the barrier and surge protection can also be added on individual outgoing spurs by the use of individual Spur Surge protection modules (part no. FS32).

An optional Trunk Surge module (part no. 9376-SP) can be plugged into the TTA to protect the fieldbus barrier against damaging voltage and current surges on the incoming trunk wiring.

The enclosures may be installed in a Zone 1 or Zone 2 hazardous area; in which case, the trunk wiring must be implemented using suitably protected cable.

The polished stainless steel enclosures provide excellent chemical and moisture resistance and are suitable for use in a wide range of corrosive environments.

The 937x-FB-XX-SS fieldbus barrier enclosures are bus-powered and they require no additional power supply in the field. When used with a fieldbus host control system, power for the trunk may be provided by MTL-Relcom F800 or FPS Series redundant power supplies.

The enclosures are supplied pre-drilled for all trunk and spur cable entries and fitted with Ex e certified blanking plugs and a breather .

## 3 MECHANICAL INSTALLATION

See Figures 3.1 and 3.2 for the dimensions, fixing locations and cable gland positions for both enclosure models.

### 3.1 Mounting overview

Before mounting an enclosure, consider the following points.

- a) The permitted ambient temperature range external to the enclosure ( $-40^{\circ}\text{C}$  to  $+70^{\circ}\text{C}$ ) must not be exceeded. Avoid radiant heat by locating the enclosure away from direct sunlight or local sources of heat.
- b) The enclosure has an ingress protection rating of IP65 (to EN60529) so the mounting location should be chosen to comply with this rating.
- c) The enclosure is designed for mounting on a vertical surface, with the cable entry at the lowest point, as shown in the upper part of Figure 3.1 or Figure 3.2.
- d) Adequate security should be provided against unauthorised interference.
- e) All the necessary gland holes have been prepared in the enclosure. One has a breather fitted and the others are fitted with appropriate blanking plugs. Where the blanking plugs are replaced by cable gland, the fitted glands must be Ex e certified and have an ingress protection (IP) rating that maintains the overall rating of the enclosure.
- f) All cable gland holes must be fitted with either a suitable cable gland or blanking plug.

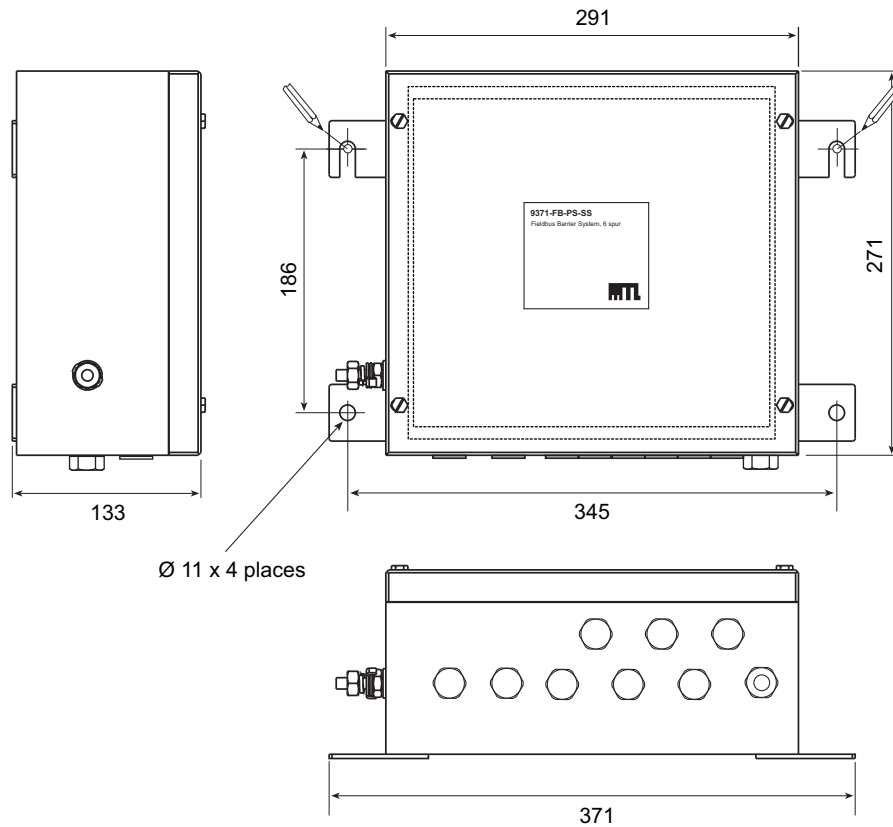

Figure 3.1 - External dimensions and mounting hole positions for the 6-way enclosure (9371-FB-XX-SS)

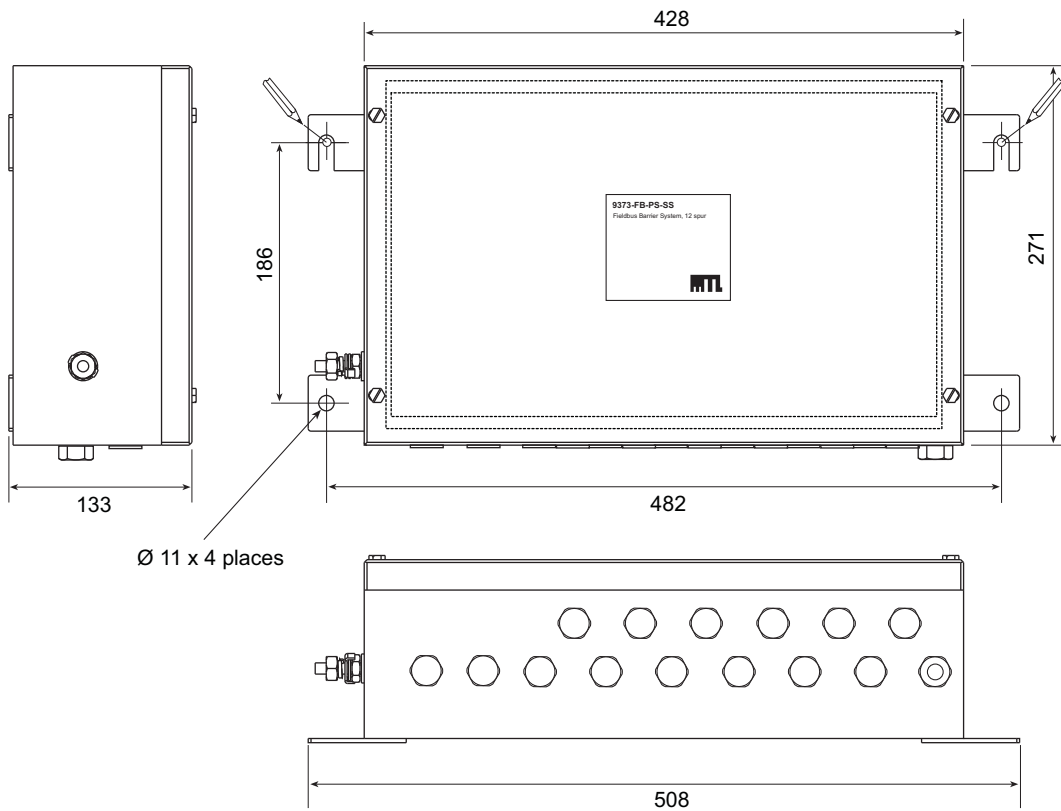

Figure 3.2 - External dimensions and mounting hole positions for the 12-way enclosure (9373-FB-XX-SS)

### CAUTION

**It is not permitted to create additional holes in the enclosure as this would violate the certification.**

## 3.2 Preparation

- a) Remove any temporary protection or packing materials.
- b) The enclosure can be mounted on any suitable structure using the enclosure's integral mounting brackets.
- c) The fixing bolts must be suitable for the mounting surface and the environmental conditions.
- d) Prepare holes in the mounting surface, on the centres shown in Figure 3.1 or 3.2, to accept suitable screws/bolts for mounting.
- e) It is advisable before mounting, to do any necessary replacement of the cable entry blanking plugs with a suitable gland. For further details see Section 3.1 e) & f).

## 3.3 Mounting

### CAUTION

**To minimise the risk of ignition by electrical apparatus in hazardous areas, efficient installation, inspection and maintenance of apparatus and systems is essential, and the work should be carried out by suitably trained personnel in accordance with the prevailing code of practice.**

**The certification documents specify "Conditions for safe use" that must be adhered to and the copy certificate supplied should be studied and understood. Additionally it is recommend that a working knowledge of IEC EN 60079 -14 be attained, as this standard provides guidance in respect to the installation of electrical equipment in hazardous areas.**

### 3.3.1 Fixing the enclosure to a surface

The enclosure can be used as a template. With help from at least one other person, hold it in the position required and mark the surface through the top slotted lugs only (as shown in Figures 3.1 and 3.2). Open up these hole positions to a suitable size and depth.

#### For concrete/masonry

- a) Fit washers onto two expanding fixing bolts and screw the bolts into prepared holes to a depth that will allow the enclosure to be safely hung on them.
- b) Support the enclosure on these top bolts and mark the lower fixing points on the mounting surface through the mounting lugs.
- c) Remove the enclosure and put it to one side. Open up, to a suitable size and depth, the hole positions that were marked on the mounting surface.
- d) Re-hang the enclosure on the top bolts and fit the bottom fixing bolts (and washers) for the lower lugs and secure them.
- e) Finally, tighten all fixing bolts to the manufacturers recommended torque value.

#### For a steel structure

- a) After marking and preparing the top holes, put the enclosure in position and fix it with bolts, washers and nuts.
- b) Drill through the holes in the bottom lugs and fit the fixing bolts as for the top lugs.

#### After mounting the enclosure

Check that:

- it has not suffered any damage,
- the IP rating is not affected; for example, by distortion of the enclosure,
- the mounting bolts/nuts are all tightened as recommended above.

## 4 INITIAL ELECTRICAL INSTALLATION

### WARNING!

**Before starting any electrical installation work, ensure that the incoming trunk connection is isolated from any source of power.**

### CAUTION

**Enclosure temperatures could rise to 75°C. Ensure that all cables and cable glands fitted are rated to withstand these temperatures.**

### 4.1 Overview

Obtain access to the contents of the enclosure by removing the lid which is secured to the body of the enclosure by captive screws. Loosen these screws to obtain entry.

### CAUTION

**The lid is connected to the enclosure body with a protective grounding cable. DO NOT leave the lid hanging by this link cable while work is carried out!**

- The enclosure receives power from the incoming trunk cable and requires no further source of power.
- The equipment shall only be powered from supplies conforming to IEC 61158.
- Type 'A' fieldbus cable is recommended for fieldbus trunk connections.
- The terminal blocks for the trunk fieldbus cables have either screw terminal connectors or cage clamp connectors according to the enclosure model specified, but both are suitable for cables from 0.5mm<sup>2</sup>/AWG 20 up to 2.5mm<sup>2</sup>/AWG 14.

Check all blanking plugs and cable glands are tightened to ensure at least an IP65 rating.

For details of the enclosure wiring for the two system types see Appendix 1.

### 4.2 Grounding

Two distinct ground concepts should be recognised before wiring of the enclosure begins:

- a) Local protective earth-ground - mandatory
- b) Cable shield

These two concepts and their implementation are explained below.

#### 4.2.1 Protective local ground

This ground connection is required to ensure that any exposed metal work in, or on, the enclosure does not present a hazard to personnel; it also provides a low impedance earth grounding circuit for any surge protection items used in the enclosure. An M8 earth-grounding stud is provided on the side wall of the enclosure to enable a connection to be made to the local ground.

Use a ring terminal to make a good quality, plant safety earth connection (4mm<sup>2</sup> cross-sectional area or better) to this bolt and tighten it to a recommended torque of 5Nm.

**Note:** It is important to prevent this connection from loosening and also to protect it from corrosion against the stainless steel grounding stud.

#### 4.2.2 Cable shield ground

The cable shield is normally electrically isolated from the protective earth ground, although the two may be deliberately interconnected in some grounding arrangements. The cable shield wiring of the trunk and spur cables should be connected to the local terminals marked with an 'S'.

The enclosures can be configured by the user to one of four different grounding methods. The user should adopt the one that conforms to their system's normal grounding method.

Whichever method is used, it is important to connect the screen/shield to a ground at only one end of the cable.

The following options are available to the user.

<b>WARNING!</b>
<b>The following may involve changes to wiring in the Trunk Terminal Assembly. No part of the Trunk Terminal Assembly may be worked while the enclosure is powered, unless the environment is known to be non-hazardous.</b>

**4.2.2.1 Single point of grounding at host; trunk & spur shields interconnected**

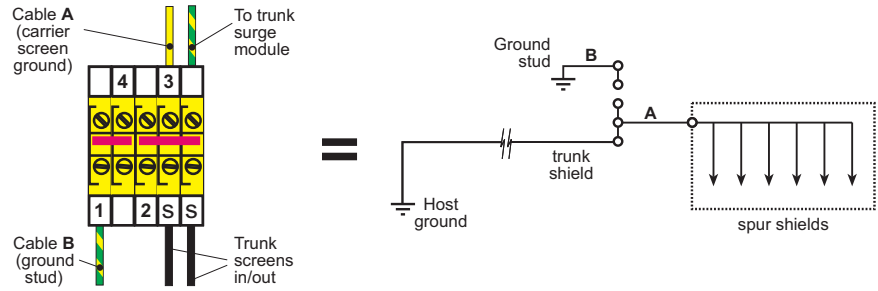
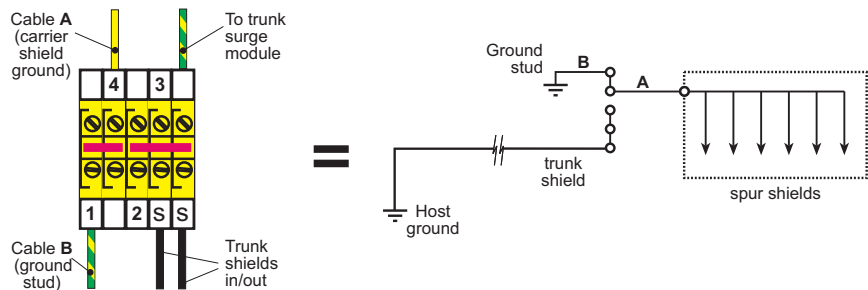

**Figure 4.1 - Option 1**

In many installation, the preferred method of grounding is to ground the fieldbus cable shields at one point only, normally at the fieldbus power supply. In this case, the trunk and spur cable shields are connected to each other at the Fieldbus Barrier and are not connected to ground in the field. For this arrangement, connect the local ground wire (marked B) into Terminal 1 and the carrier shield ground wire (marked A) into Terminal 3.

**Note: this is the default grounding method for factory-supplied 937x-FB enclosures.**

**4.2.2.2 Trunk shield grounded at host; spur cable shields grounded at barrier**



**Figure 4.2 - Option 2**

With this arrangement, the fieldbus trunk shield is separated from the spur cable shields. It should be adopted if plant or local regulations require that the spur cable shields be grounded at the Fieldbus Barrier. For this arrangement, connect the local ground wire (marked B) into Terminal 1 and the carrier shield ground wire (marked A) into Terminal 4.

**4.2.2.3 Multiple points of grounding**

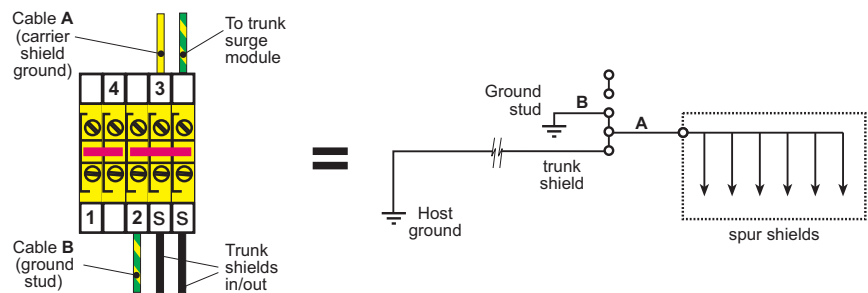

**Figure 4.3 - Option 3**

In installations where potential equalisation is known to provide a consistent, low impedance ground plane throughout the plant, the fieldbus cable shields may be grounded at more than one point. With this arrangement, the trunk and spur cable shields are interconnected and grounded at Fieldbus Barrier enclosure as well as at the host. For this arrangement, connect the local ground wire (marked B) into Terminal 2 and the carrier shield ground wire (marked A) into Terminal 3.

#### 4.2.2.4 Single point of grounding at barrier: trunk & spur shields interconnected

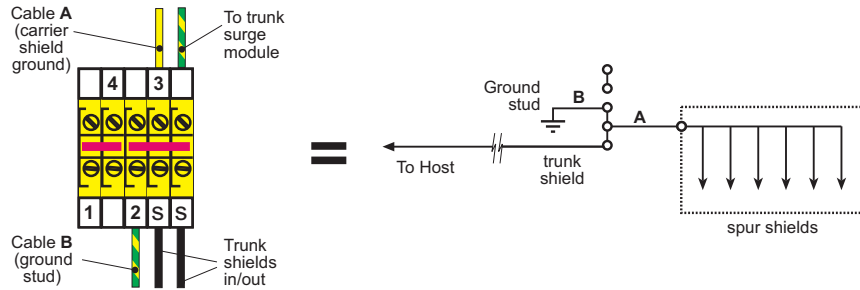

**Figure 4.4 - Option 4**

This grounding option uses the local protective ground at the Fieldbus Barrier to ground both the trunk cable shield and the spur cable shields. No ground is provided for the trunk cable shield at the host end. For this arrangement, connect the local ground wire (marked B) into Terminal 2 and the carrier shield ground wire (marked A) into Terminal 3.

**Note:** After configuring the required grounding option, tighten all screw terminals to a recommended torque of 0.6 Nm.

### 4.3 Trunk connections

Each enclosure is provided with two access holes for trunk glands; one for the incoming trunk and another for onward linking to an additional enclosure, if necessary.

<b>WARNING!</b>
<b>No part of the Trunk Terminal Assembly may be worked while the enclosure is powered, unless the environment is known to be non-hazardous.</b>

#### 4.3.1 Trunk Terminal Assembly

Inside the enclosure, the trunk cables are terminated in a Trunk Terminal Assembly (TTA). This is a sub-enclosure with a protective lid, secured with a single screw. This assembly, together with its warning label, is intended to deter a user from working on the trunk connections without isolating trunk power. See Figure 4.6.

Trunk cables enter via glands, through the enclosure wall shown at the bottom of the diagram, and the grounding stud is accessible on the lower left side. The trunk terminal connectors are in the middle of the assembly to receive the trunk wiring.

Depending upon model type chosen, the enclosure will accommodate 6 or 12 spurs.

#### 4.3.2 Permitted enclosure combinations

The maximum number of intrinsically safe spurs that can be supported per segment using 9370-FB Series Fieldbus Barriers is 12. A 12-spur enclosure (9373-FB) will therefore *always* require a fieldbus terminator (9378-FT) to be fitted to the Trunk Terminal Assembly.

The permitted enclosure combinations are shown in Figure 4.5. See also Figure 4.6 and Section 4.4.

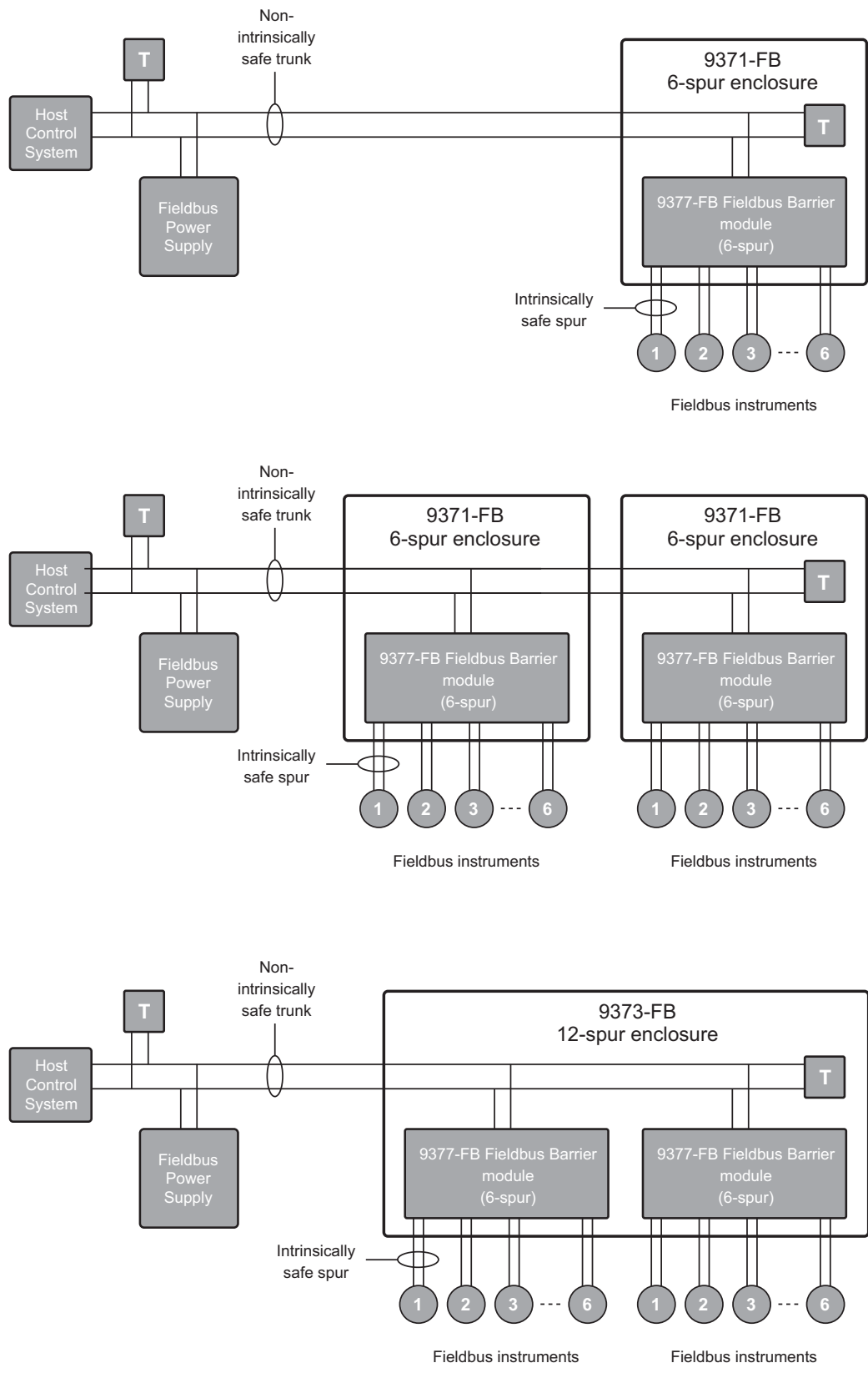

**Figure 4.5 - Trunk Connection Options**

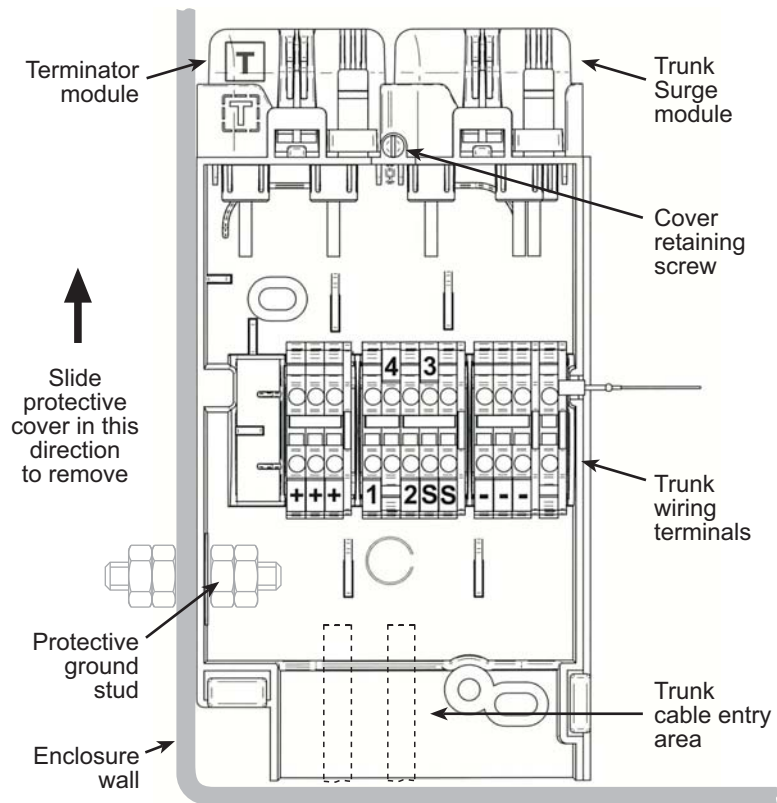

**Figure 4.6 - Trunk Termination Assembly (TTA)**

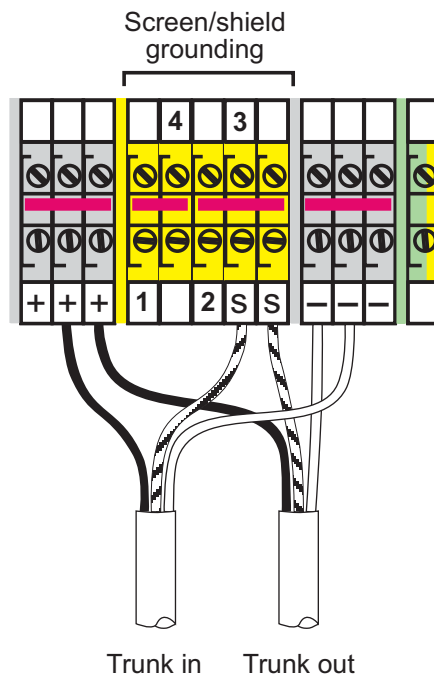

**Figure 4.7 - Trunk Cable Connections in TTA**

Connect the trunk cable(s) in the following way.

- a) Loosen the captive screw of the transparent protective cover on the TTA. Slide out the cover and move it to one side to obtain access.
- b) Prepare the trunk cable(s) in accordance with the gland manufacturer's instructions and secure the cable(s) in the gland(s). Ensure that the cables are not strained.
- c) Connect the prepared ends of the fieldbus trunk cable(s) into the appropriate '+', '-' and 'S' terminals, shown in Figure 4.7, and tighten the screw terminals to a recommended torque of 0.6 Nm.

**Note:** Figure 4.7 shows the screw-terminal '-PS' enclosure option, but the '-PC' cage-clamp terminal arrangement is similar.

- d) Check Section 4.2.2 to confirm that the chosen fieldbus-ground option is correctly wired, and adjust if necessary.
- e) Replace the transparent protective cover over the terminal block and secure it with the retaining screw to a recommended torque of 0.6 Nm.

#### 4.4 Trunk Terminator module 9378-FT

If the enclosure provides the last (or only) spur connections on the segment, the trunk must be terminated correctly to ensure that the optimum signal quality is maintained. The Trunk Termination Assembly (TTA) has provision for an 9378-FT Terminator module to be fitted when required.

##### INFORMATION

**A terminator should be used only at the end points of the trunk wiring. Connecting a terminator at any other point on the trunk will degrade the signal.**

The 9378-FT is a two-pin module that plugs into the upper end face of the Trunk Terminator Assembly. See Section 5.3 for fitting and removal details.

#### 4.5 Trunk Surge module 9376-SP

The 9376-SP Trunk Surge module can be fitted to the TTA to prevent damage to the equipment from voltage and current surges that could occur on the trunk wiring.

The 9376-SP is a four pin module that plugs into the upper end face of the Trunk Terminator Assembly. See Section 5.4 for fitting and removal details.

#### 4.6 Spur connections

Refer to Figures 4.8 for additional details.

The spur cables can be connected directly onto the fieldbus barrier carrier or through a Spur Surge module (FS32).

If Spur Surge modules are not being used, sub-section 4.6.2 can be ignored.

##### 4.6.1 Connecting the spur cables

Prepare the spur cables in accordance with the gland manufacturer's instructions and secure the cables in the glands.

##### IMPORTANT

- When fitting the cable in the gland allow at least 20 – 30mm of available cable length outside the enclosure to allow for cable adjustment if a Spur Surge module is taken out of circuit inside the enclosure. See Section 5.5.1 for further details
- Cable ferrules must be fitted to any stranded cable or screen wiring that is being used.

Connect the prepared ends of the fieldbus spur cables into the '+', 'S' and '-' terminals on the carrier (or surge module, if fitted), making sure that the same polarity is observed for all spurs.

#### 4.6.2 Fitting FS32 Spur Surge modules

Spur Surge modules are pluggable units that integrate easily with the standard pluggable connector and which direct excessive spur surge currents to the protective local ground.

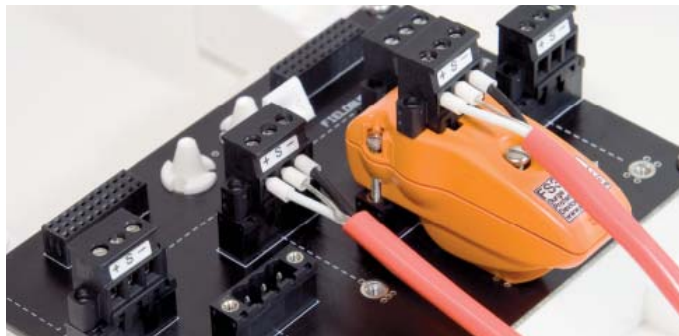

**Figure 4.8 - FS32 Spur Surge module on carrier**

To fit an FS32:

1. Unscrew the two captive screws securing the standard pluggable connector (supplied on the carrier) and remove it from its socket.
2. Insert the FS32 module into the now vacant socket on the carrier, tighten the two side securing screws and the central "protective ground" screw, to a recommended torque of 0.4 Nm.
3. Fit the connector (removed at Step 1 above) into the socket on the FS32 and tighten its two securing screws also to a recommended torque of 0.4 Nm.

Removal of a Spur Surge module is the reverse of the fitting process. See also Section 5.4.1 on page 14 for information on cable 'adjustment' if one of these modules is taken out of use.

#### 4.7 Final checks

Before replacing the lids on the enclosure, check:

- that all cable glands and any blanking plugs are tightened securely.
- that there are no loose cable ends that could cause an open or short circuit.
- that the protective trunk wiring cover is in place on the Trunk Terminal Assembly.
- that no tools (e.g. screwdrivers) or loose items have been left in the enclosure.
- that there is no damage to any cover seal, otherwise it must be replaced with one that has the same manufacturer's part number.
- that if, and only if, the enclosure *is the last one* on the fieldbus segment, that a 9378-FT Terminator module is fitted into the socket on the TTA.
- that the required grounding link is securely connected between the enclosure lid and the enclosure body.

Fit the enclosure lid and tighten all of its securing screws to a recommended torque of 2.5 Nm.

## 5 MAINTENANCE

When the enclosure is installed in a hazardous area it is important for personnel to understand what activities are permissible when fieldbus power is present and what are not.

### WARNING!

**Read and understand what work is permitted inside the enclosure. Failure to comply with these instructions can endanger the lives or health of personnel and risk damage to the plant and the environment.**

### 5.1 General

The following items in the enclosure may be removed or disconnected while the trunk is still powered.

- 9377-FB Fieldbus Barrier module(s)
- 9378-FT Terminator module
- 9376-SP Trunk Surge module
- FS32 Spur Surge modules and any spur wiring

All other wiring in the enclosure requires the trunk power to be isolated, or a gas clearance certificate to be obtained before any work is carried out.

### 5.2 Fieldbus Barrier - fitting and removal

The 9377-FB Fieldbus Barrier module(s) may be fitted or removed without the need to isolate trunk power. The trunk connections to the barrier module on the carrier have spark suppression by design and cannot cause ignition while they are being connected or disconnected.



**Figure 5.1 - Fieldbus Barrier module - fitting & removal**

#### **Fitting a Fieldbus Barrier module** (refer to Figure 5.1)

**Note:** Before fitting a 9377-FB Fieldbus Barrier module check the connection pins on its underside to ensure that they have not been bent or damaged in any way.

- a) Engage the locating guides of the 9377-FB Fieldbus Barrier module into the sockets provided on the carrier and push the module fully into place.
- b) Tighten the captive fixing screws on each side and at the top of the module (to a recommended torque of 0.9Nm) to secure it.

## Removing a Fieldbus Barrier module

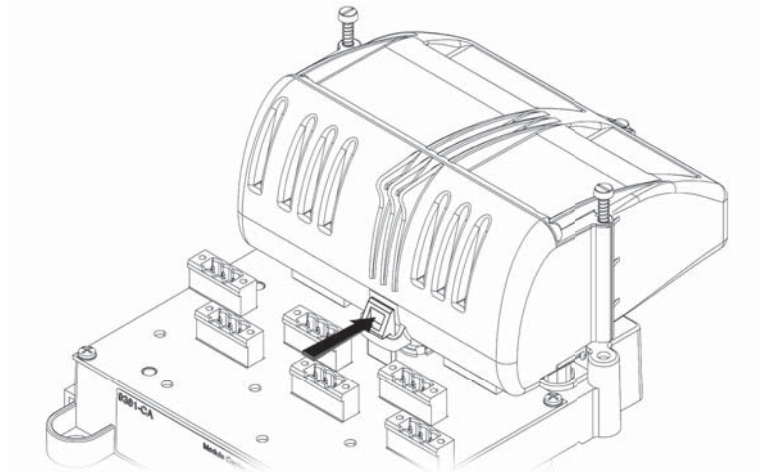

**Figure 5.2 - Safety retaining clip for barrier**

- Loosen the three captive fixing screws on the module to release it. The screws are spring-loaded and should retract when the thread has disengaged.
- Slowly pull the 9377-FB Fieldbus Barrier module away from its connections on the carrier until the safety retaining clip stops further removal. See Figure 5.2.
- Press the clip towards the module until the barrier is released and can be removed completely.

## 5.3 Terminator and Trunk Surge Protection modules

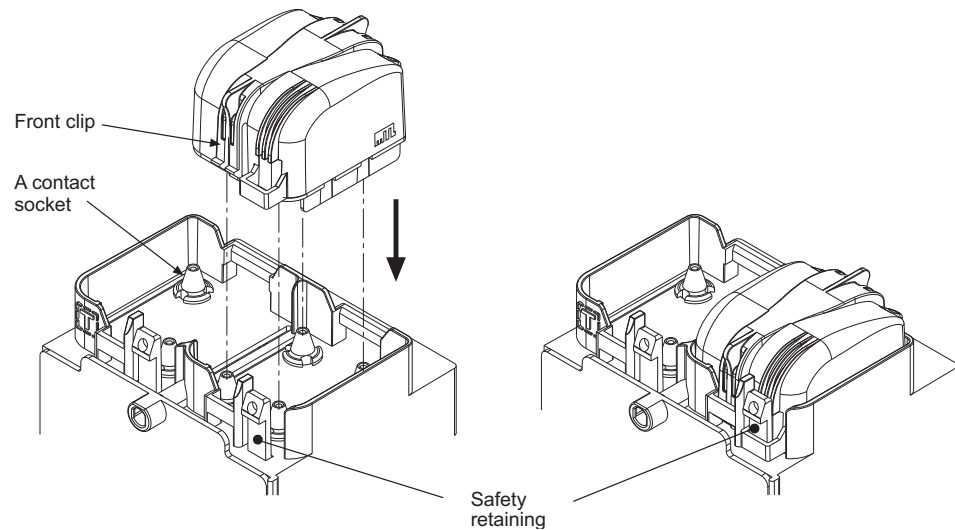

**Figure 5.3 - Module connectors and retaining clips**

### 5.3.1 Fitting and removal

Both modules have connectors that are designed to prevent an ignition-capable spark when the module is installed or removed. The modules are not interchangeable but the method of installing and removal is the same.

**Do not use**, or attempt to repair, a module that has any of the pins on its underside *bent or damaged*, because this might affect its safety and invalidate the certification.



**Figure 5.4 - Mounting a module - e.g. Trunk Surge Protection module**

#### **5.3.1.1 Mounting a module**

Refer to Figure 5.4.

Orientate the module so that the smaller front clip is facing the user, then:

- lower the module so that the safety retaining clip on the TTA housing fits into the loop on the module
- locate the terminal pins into their contact sockets on the TTA housing and
- push the module home until front and rear retaining clips engage.

#### **5.3.1.2 Removing a module**

Refer to Figures 5.3 and 5.4 for further information.

Removal is a two-step process that first breaks the electrical connection, followed by the physical removal of the module from the TTA.

- Press the clip at the rear of the module and tilt the module forward until the clip disengages at the rear
- Press the front clip and withdraw the module from its socket until it is stopped by the safety retaining clip
- Press down on the safety retaining clip enough to release it, then pull the module away from the TTA body without rotating or twisting it.

### **5.4 Spur connections**

All of the spur connections are intrinsically safe and therefore may be live-worked in a hazardous area without 'gas clearance', while complying with normal 'permit to work' procedures.

If spur wiring is removed from a connecting plug, ensure that the same polarity is observed when it is reconnected.

#### **5.4.1 Removing a Spur Surge module & spur cable adjustment**

If an FS32 Spur Surge module needs to be removed from circuit, it will probably be necessary to increase the cable length inside the enclosure slightly to allow the spur wiring connector to be plugged into the circuit board. Use the following procedure.

- a) Loosen the two screws securing the pluggable, spur-wiring connector to the Spur Surge module and unplug it.
- b) Loosen all three of the Spur Surge module's fixing screws and unplug it from the carrier.
- c) Loosen the spur cable gland.

- d) Pull an additional 20 mm (approx.) of additional cable length into the enclosure.
- e) Plug the spur connecting plug into its mating socket on the barrier carrier and tighten the fixing screws to a recommended torque value of 0.4 Nm.

Make any final adjustments to the cable, to avoid any tension, then tighten the spur cable gland to clamp the cable to retain the IP rating of the enclosure.

#### 5.4.2 Adding a Spur Surge module & spur cable adjustment

If an FS32 Spur Surge module is added, it will probably be necessary to reduce the cable length inside the enclosure slightly when connecting the spur wiring connector to the Spur Surge module. Refer also to Section 4.6.1 for further fitting details.

- a) Loosen the two screws securing the pluggable, spur-wiring connector to the carrier and unplug it.
- b) Plug the Spur Surge module into the vacant socket on the carrier and tighten the two fixing screws and its grounding screw, all to a recommended torque of 0.4 Nm.
- c) Loosen the spur cable gland.
- d) Withdraw approximately 20 mm of the cable length from the enclosure.
- e) Plug the spur connecting plug into its mating socket on the Spur Surge module and tighten the fixing screws to a recommended torque of 0.4 Nm.

Make any final adjustments to the cable, to avoid any tension, then tighten the spur cable gland to clamp the cable to retain the IP rating of the enclosure.

### 5.5 Trunk connections

<b>WARNING!</b>
<b>No work is permitted on any part of the Trunk Terminal Assembly while the enclosure is powered, unless the environment is known to be non-hazardous.</b>

Gaining access to the contents of the Trunk Terminal Assembly requires the trunk power to the enclosure to be isolated, or a gas clearance certificate obtained.

Once the conditions are known to be safe, the protective plastic cover of the Trunk Terminal Assembly (TTA) may be removed. Unscrew its securing screw, slide it out until it becomes free and then move it to the side to obtain access.

Refer to Section 4.2.1 for additional information about trunk wiring connections.

When any changes or checks have been carried out, ensure there are no loose implements left inside the TTA before replacing its protective cover. Slide the cover into its locations and tighten the securing screw to a recommended torque of 0.6 Nm.

### 5.6 Regular Maintenance checks

Check the general condition of the installation occasionally to ensure that no deterioration has occurred. At least every two years (and more frequently for harsh, dusty or dirty environments) check:

- the condition of all wire connections/terminations/screens.
- that the dc output voltage on the fieldbus trunk, when measured at the enclosure, is >16V. This can be performed using a multimeter or an FBT-6 fieldbus tester.  
**IMPORTANT:** This test requires the removal of the cover on the Trunk Terminal Assembly, and **can only be carried out if the area is known to be non-hazardous.**
- that all of the fixing and cover screws and blanking plugs are secure and the breather is clear.
- that there are no signs of damage or corrosion.
- that the level of accumulated dust on the enclosure does not exceed 5mm.

## 6 TROUBLESHOOTING

The Fieldbus Barriers inside the enclosure are fitted with LED indicators to assist the user in fault identification.

Consult the following tables to understand the meaning of the LED states.

### Power LED (Green)

ON	OFF
Trunk power applied	Insufficient or no trunk power

#### CAUTION!

The **Power LED** will not light until the voltage at the barrier has risen to a value of at least 15.7V, *but could remain lit even after the voltage has dropped to around 13.0V*. DO NOT assume the Power LED indicates a voltage of 16V or more.

If the green Power LED is not lit, check:

- the polarity and integrity of the trunk cable connections to the enclosure.
- that the power supply is operating correctly.

### Spur LEDs

Colour	State	Description
Green	Steady	Channel powering spur, spur OK
Green	Flashing	Channel powering spur, spur open
Red	Steady	Internal fault
Orange	Steady	Short to shield
Orange	Flashing*	Short circuit, current limit

\* Flashing occurs at a rate of approximately 2 pulses per second.

## 7 ATEX INFORMATION

The Essential Health and Safety Requirements (Annex II) of the EU Directive 94/9/EC [the ATEX Directive - safety of apparatus] requires that the installation manual of all equipment used in hazardous areas shall contain certain information. This annex is included to ensure that this requirement is met. It complements the information presented in this document and does not conflict with that information. It is only relevant to those locations where the ATEX directives are applicable.

### 7.1 General

- a) In common with all other electrical apparatus installed in hazardous areas, this apparatus must only be installed, operated and maintained by competent personnel. Such personnel shall have undergone training, which included instruction on the various types of protection and installation practices, the relevant rules and regulations, and on the general principles of area classification. Appropriate refresher training shall be given on a regular basis. [See clause 4.2 of EN 60079-17].
- b) The apparatus has been designed and manufactured so as to provide protection against all the relevant additional hazards referred to in Annex II of the Directive, such as those in clause 1.2.7.
- c) This apparatus has been designed to meet the requirements of electrical apparatus in accordance with EN 60079-0, EN 60079-1, EN 60079-7, EN 60079-11, EN 60079-18 and EN 60079-31.

### 7.2 Installation

- a) The installation should comply with the appropriate European, national and local regulations, which may include reference to the IEC code of practice IEC 60079-14. In addition particular industries or end users may have specific requirements relating to the safety of their installations and these requirements should also be met. For the majority of installations the Directive 1999/92/EC [the ATEX Directive - safety of installations] is also applicable.
- b) The junction boxes are certified:  
⊕ II 2(1)GD Ex d e i b mb [ia Ga] IIC T4 Gb (-40°C to +75°C) Ex tb IIIC T80°C Db and are designed for installation in Zone 1 or Zone 2 hazardous areas.
- c) The apparatus must not be subjected to mechanical and thermal stresses in excess of those permitted in the certification documentation, this manual and the product specification.
- d) All cables and their glands must be chosen to withstand the temperatures at which the apparatus is designed to operate. See product specification for details.
- e) The apparatus must not be installed in a position where it may be attacked by aggressive substances.

### 7.3 Inspection and maintenance

- a) Inspection and maintenance should be carried out in accordance with European, national and local regulations which may refer to the IEC standard IEC 60079-17. In addition specific industries or end users may have specific requirements which should also be met.
- b) Care should be taken to limit dust accumulation on the exterior of the apparatus to a depth not exceeding 5mm.
- c) Maintenance of internal components while powered is limited to those actions permitted in Section 5 of this manual.

### 7.4 Repair

The modules used in this product cannot be repaired by the user and must be replaced with an equivalent certified product.

### 7.5 Marking

Each certified component is marked in compliance with the Directive and CE marked with the Notified Body Identification Number.

This information applies to products manufactured during or after the year 2010.

## Enclosure labels

### 9371-FB

#### Fieldbus Barrier System, 6 spur, Stainless Steel Enclosure

Baseefa 09ATEX0185X

-40°C < Ta < +70°C

 II 2(1) GD

FISCO Power supply  
(spurs)

IECEX BAS 09.0082X

Ex d e ib mb [ia Ga] IIC T4 Gb

Ex tb IIIC T80°C Db

WARNING:- NON-INTRINSICALLY SAFE CIRCUITS PROTECTED  
BY INTERNAL IP30 COVER.



SEE INSTRUCTION  
MANUAL

3995/1

Measurement Technology Ltd  
Luton, England. Made in England.  
www.mtl-inst.com



### 9373-FB

#### Fieldbus Barrier System, 12 spur, Stainless Steel Enclosure

Baseefa 09ATEX0185X

-40°C < Ta < +70°C

 II 2(1) GD

FISCO Power supply  
(spurs)

IECEX BAS 09.0082X

Ex d e ib mb [ia Ga] IIC T4 Gb

Ex tb IIIC T80°C Db

WARNING:- NON-INTRINSICALLY SAFE CIRCUITS PROTECTED  
BY INTERNAL IP30 COVER.



SEE INSTRUCTION  
MANUAL

3999/1

Measurement Technology Ltd  
Luton, England. Made in England.  
www.mtl-inst.com



## **8 APPENDIX 1 - ENCLOSURE WIRING DIAGRAMS**

Wiring diagram for 9371-FB-XX-SS

page 20

Wiring diagram for 9373-FB-XX-SS

page 21

## 8.1 Wiring diagram for 9371-FB-XX-SS

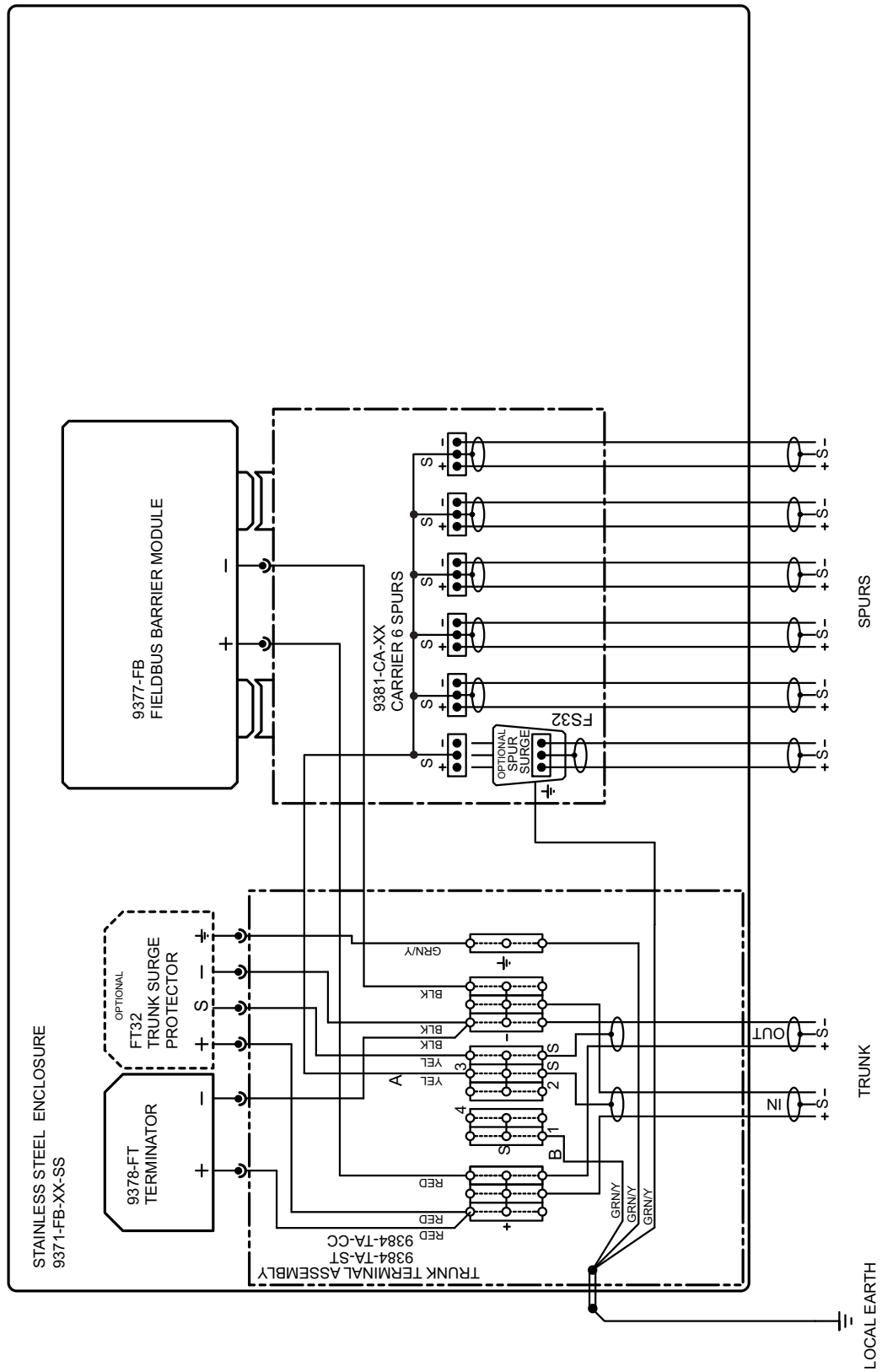

NOTE: FACTORY DEFAULT GROUNDING OPTION SHOWN - I.E. SINGLE POINT GROUNDING AT HOST

## 8.2 Wiring diagram for 9373-FB-XX-SS

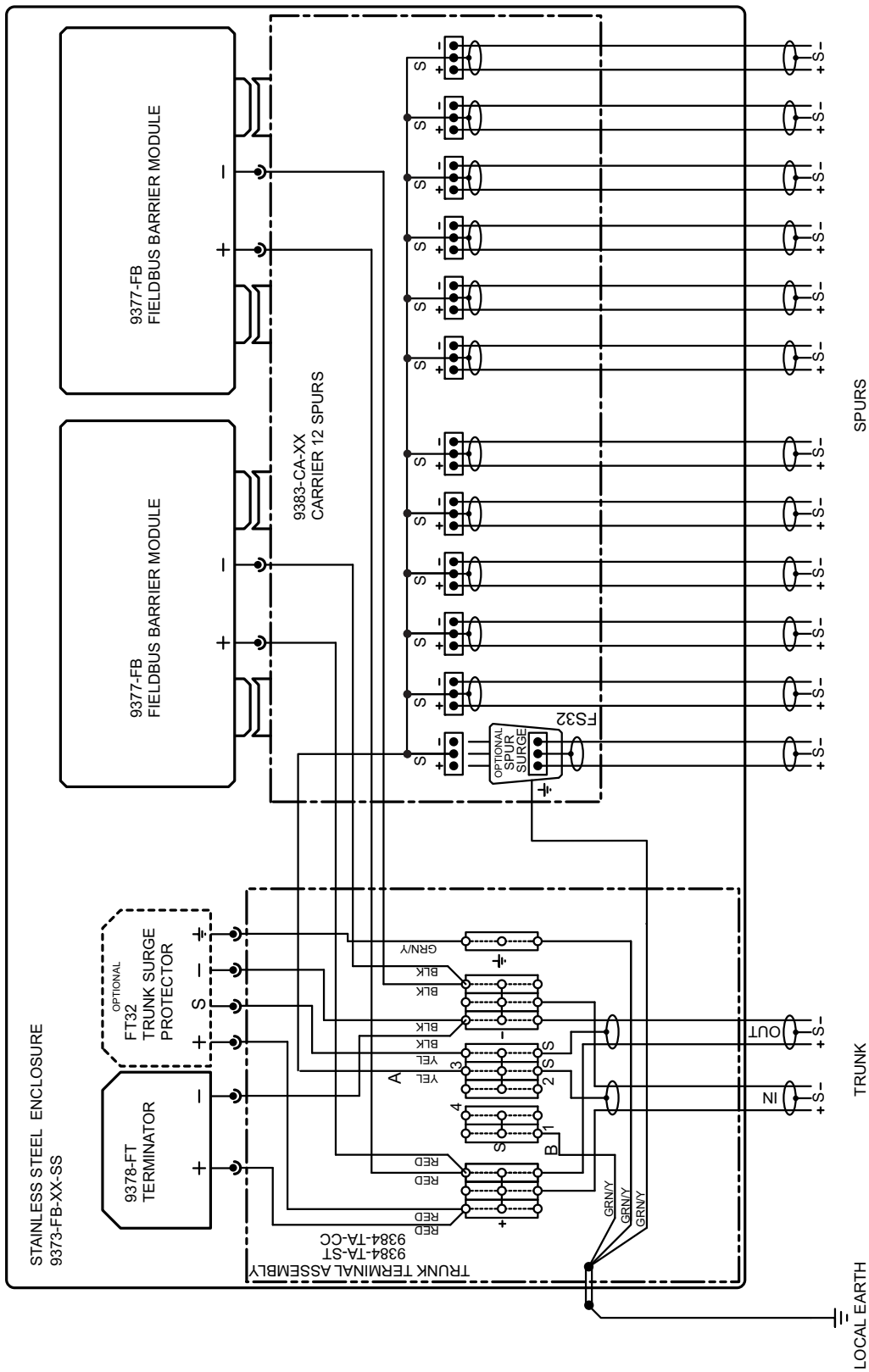

**This page left intentionally blank**

**This page left intentionally blank**

**MTL Instruments Pty Limited**

9 /12 Billabong Street  
Stafford  
Queensland 4053  
Australia  
Tel: + 61 1300 308 374 Fax: + 61 1300 308 463  
E-mail: enquiries@mtlaus.com.au

**Cooper Electric (Shanghai) Co.Ltd.**

Room 2001, China Life Tower  
16 Chao Yang Men Wai Street  
Chao Yang District, Beijing  
China 100020  
Tel: + 86 10 5980 0288 Fax: + 86 10 8562 5725  
E-mail: bjsales@mtl-inst.cn

**MTL Instruments sarl**

Les Carrés du Parc  
10 rue des Rosiéristes  
69410 Champagne au Mont d'Or  
France  
Tel: +33 (0)4 78 64 98 32 Fax: +33 (0)4 78 35 79 41  
E-mail: info@mtl-inst.fr

**MTL Instruments GmbH**

An der Gumpgesbrücke 17  
D-41564 Kaarst  
Germany  
Tel: +49 (0)2131 718930 Fax: +49 (0)2131 7189333  
E-mail: info@mtl.de

**MTL India**

No. 36, Nehru Street  
Off Old Mahabalipuram Road  
Sholinganallur  
Chennai - 600 119  
India  
Tel: + 91 (0)44 24501660/24501857 Fax: + 91 (0)44 24501463  
E-mail: sales@mtlindia.com

**MTL Italia srl**

Via Cantù 11  
I - 20092 Cinisello Balsamo MI  
Italy  
Tel: +39 (0)2 61802011 Fax: +39 (0)2 61294560  
E-mail: info@mtl-inst.it

**MTL Instruments KK**

MT Building 3F  
2-7-5 Shiba Daimon  
Minato-ku Tokyo  
Japan 105-0012  
Tel: +81 (0)3 6430 3128 Fax: +81 (0)3 6430 3129  
E-mail: sales@mtlkk.co.jp

**Cooper Crouse-Hinds Korea**

12F, Vision Tower  
707-2 Yeoksam-dong, Gangnam-gu  
Seoul 135-080  
South Korea  
Tel: +82 2 3484 6795 Fax: +82 2 3484 6778

**MTL Instruments BV**

MTL Instruments BV  
Terheijdensweg 465  
4825BK Breda  
The Netherlands  
Tel: +31(0)76 7505360 Fax: +31(0)76 7505370  
E-mail: info@mtlbenelux.com

**Cooper Crouse-Hinds Pte Ltd**

No.2 Serangoon North Avenue 5  
#06-01 Fu Yu Building  
Singapore 554911  
Tel: +65 6 487 7887 Fax: +65 6 487 7997  
E-mail: sales@mtlsing.com.sg

**MTL Instruments**

Villa No. 4, Sector 2-17, Street 6  
PO Box 53234,  
Abu Dhabi, UAE  
Tel: +971 2 446 6840 Fax: +971 2 446 6841  
E-mail: mtlgulf@mtl-inst.com

**Measurement Technology Limited**

Great Marlings, Butterfield, Luton, Beds  
England LU2 8DL  
Tel: +44 (0)1582 723633 Fax: +44 (0)1582 422283  
E-mail: enquiry@mtl-inst.com

**MTL Incorporated**

3413 N. Sam Houston Parkway W.  
Suite 210  
Houston TX 77086  
USA  
Tel: +1 281 571 8065 Fax: +1 281 571 8069  
E-mail: csinfo@mtl-inst.com

